

Model

Designation	DLE5.7CN	220-240V/50Hz 1~	Sales code:	102H4653
-------------	-----------------	-------------------------	-------------	-----------------

Compressor design

Oil type	Polyolester	Refrigerant(s)	R290
Oil viscosity	32cSt	Displacement	5,7cm ³ / 0,35cu.in
Oil quantity	221cm ³ / 7,5fl.oz	Compressors on pallet	100
Refr. charge - tech. limit	150g / 5,3oz		
Free gas volume comp.	1390cm ³ / 47fl.oz		
Weight	8,2kg / 18,1lbs		
Motor protection	1# internal		
Winding resistance main	13,53Ω (at 25°C)		
Winding resistance aux	14,27Ω (at 25°C)		
Max. winding temp.	125°C / 257°F		
Max. discharge temp.	130°C / 266°F		



General - Configurations with DLE5.7CN

	Conf. 1	Conf. 2	Conf. 3
Motorconfiguration	CSIR	RSIR	RSCR
Power supply (nominal)	220-240V/50Hz	220-240V/50Hz	220-240V/50Hz
Number of phases	1	1	1
Voltage range	198-254V	198-254V	198-254V
Approvals	VDE, CCC	VDE, CCC	VDE, CCC
Starting torque	HST	LST	LST
Note	- / -		

Applications with DLE5.7CN

	Conf. 1	Conf. 2	Conf. 3
Refrigerant	R290	R290	R290
Application	LBP+MBP	LBP+MBP	LBP+MBP
System cooling	fan 3m/s	fan 3m/s	static
Hot gas defrost	OK	OK	OK
Long interval pull down	OK	OK	OK

Electrical data - Configurations with DLE5.7CN

	Conf. 1	Conf. 2	Conf. 3
Starting device type	relay	PTC	PTC
Run capacitor	-/-	-/-	5μF
Start capacitor	80μF	-/-	-/-
LRA (locked rotor amps / 4s)	8,9A	7,4A	7,4A
RLA (rated load amps / 1s)	1,57A	1,57A	1,5A
Cut in current	11,92A	11,92A	11,92A
IP class	21	21	21

Model

Designation

DLE5.7CN

220-240V/50Hz 1~

Sales code:

102H4653

Compressor dimensions

Housing	A Height	174mm / 6,85in
	B Height	168mm / 6,61in
	C Length shell	183mm / 7,2in
	D Length w. cover	232mm / 9,13in
	E Width	156mm / 6,14in

Connectors		Suction	Discharge	Process
		X	Y	Z
Diameter	[mm]	øi 8,11-8,29	øi 6,11-6,29	øi 6,1-6,3
(i:inside, o:outside)	[in]	øi 0,32-0,33	øi 0,24-0,25	øi 0,24-0,25
Material		copper	copper	copper
Horizontal angle	±2°	10°	0°	0°
Vertical angle	±2°	18°	25°	119°
Position l/h/w	[mm]	135/77/67	98/96/72	-98/133/73
	[in]	5,3/3/2,6	3,8/3,8/2,8	-3,9/5,2/2,9
Straight tube l.	[mm]	12	12	12
	[in]	0,5	0,5	0,5

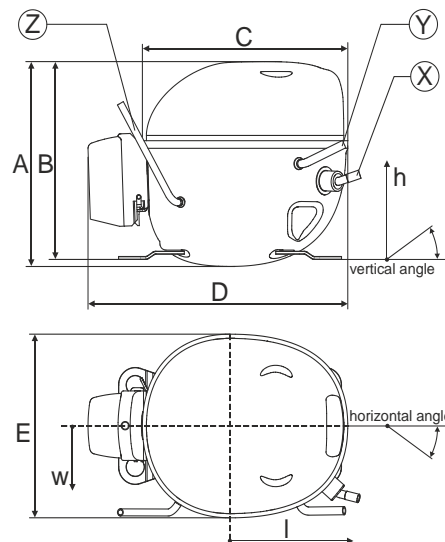

Compressor fixation

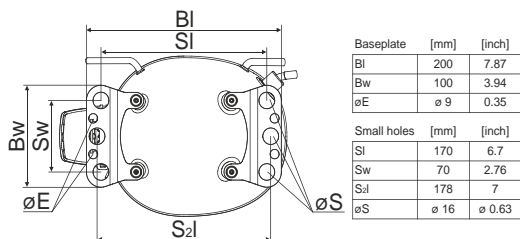

Bolt joint

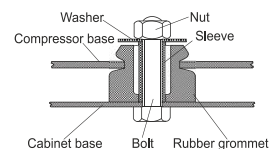

Snap-on

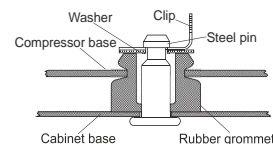

Mounting accessories

	one comp.	multi pack
Bolt joint M6 ø16mm	118-1917	118-1918
Bolt joint ø1/4" ø16mm	118-1946	
Snap-on ø7,3 ø16mm	118-1947	118-1919

Model

Designation	DLE5.7CN	220-240V/50Hz	Conf. 1	Sales code:	102H4653
-------------	-----------------	----------------------	----------------	-------------	-----------------

Configuration

Motorconfiguration	CSIR
Power supply (nominal)	220-240V/50Hz 1~
Refrigerant	R290
Application	LBP+MBP
Voltage range	198-254V
Starting torque	HST
Approvals	VDE
	CCC

Electrical accessories / wiring diagram

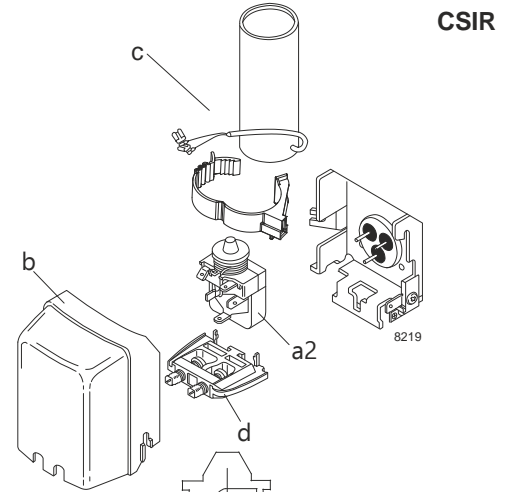

Ambient temperatures / system cooling

Ambient temperature min.:	10°C / 50°F
Ambient temperature max.:	43°C / 110°F

System cooling (n/a: outside limits)			
T ambient	LBP	MBP	HBP
32°C / 90°F	fan 3m/s	fan 3m/s	n/a
38°C / 100°F	fan 3m/s	fan 3m/s	n/a
43°C / 110°F	fan 3m/s	fan 3m/s	n/a

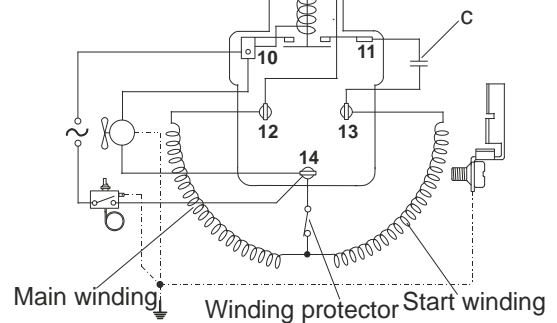

Operation pressure range

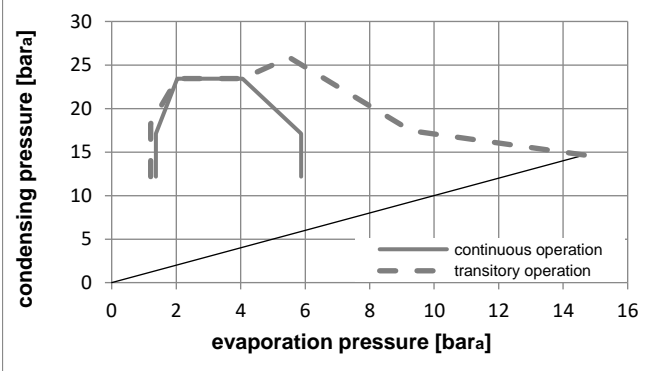
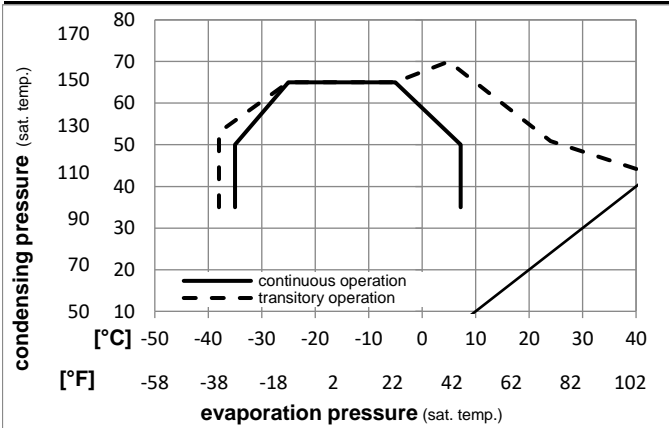

Components

a2	current relay	117U7015
c	start capacitor (80µF)	117U5015
b	plastic cover	103N0491
d	cord relief	103N1010

Model

Designation **DLE5.7CN 220-240V/50Hz** Conf. 1 Sales code: **102H4653**

Optimization + standard conditions

220-240V/50Hz 1~, CSIR, fan 3m/s, VDE, CCC

	Evaporating pressure (saturation temperature)				Condensing pressure (saturation temperature)						Power consumption			ASHRAE LBP
	pe	pc	RGT	Tliq	Cooling capacity			COP	EER	P1	I	Ref. mass flow		
	[°C]	[°C]	[°C]	[°C]	[W]	[Btu/h]	[kcal/h]	[W/W]	[Btu/Wh]	[kcal/Wh]	[W]	[A]	[kg/h]	
	-23,3	54,4	32,2	32,2	297,1	1015	255,7	1,52	5,21	1,31	194,9	1,28	3,01	ASHRAE LBP
	[-10]	130	90	90										
	-25	55	32	55	224,0	765	192,8	1,18	4,05	1,02	189,1	1,26	2,79	cecomaf LBP
	[-13]	131	89,6	131										
	-35	40	20	40	166,8	570	143,6	1,20	4,11	1,04	138,6	1,13	1,91	EN12900 LBP
	[-31]	104	68	104										
	-6,66	54,4	35	46,1	507,7	1734	437,0	1,97	6,72	1,69	258,2	1,50	5,79	ASHRAE MBP
	[20]	130	95	115										
	-10	55	32	55	405,1	1383	348,6	1,64	5,60	1,41	247,1	1,46	5,12	cecomaf MBP
	[14]	131	89,6	131										
	-10	45	20	45	446,0	1523	383,8	2,01	6,85	1,73	222,3	1,37	5,48	EN12900 MBP
	[14]	113	68	113										

Performance tables

220-240V/50Hz 1~, CSIR, fan 3m/s, VDE, CCC

	pe	Cooling capacity			COP	EER	P1	I	m		
	[°C]	[°F]	[W]	[Btu/h]	[kcal/h]	[W/W]	[Btu/Wh]	[kcal/Wh]	[W]	[A]	[kg/h]
[°C / °F]	-35	-31	162,1	554	139,5	1,14	3,90	0,98	141,9	1,13	1,82
cond. pressure	-25	-13	258,1	881	222,1	1,46	5,00	1,26	176,3	1,23	2,91
pc= 45/113	-15	5	384,5	1313	330,9	1,85	6,32	1,59	207,7	1,32	4,37
return gas temp.	-10	14	464,3	1586	399,6	2,09	7,13	1,80	222,3	1,37	5,31
RGT= 32/90	-5	23	557,9	1905	480,2	2,36	8,07	2,03	236,0	1,42	6,42
liquid temp	0	32	667,4	2279	574,4	2,68	9,16	2,31	248,8	1,47	7,74
Tliq= 45/113	7,2	45	857,2	2927	737,7	3,23	11,02	2,78	265,6	1,54	10,07
[°C / °F]	-35	-31	135,4	462	116,5	0,91	3,09	0,78	149,5	1,15	1,67
cond. pressure	-25	-13	224,0	765	192,8	1,18	4,05	1,02	189,1	1,26	2,79
pc= 55/131	-15	5	335,6	1146	288,8	1,47	5,03	1,27	228,0	1,39	4,22
return gas temp	-10	14	405,1	1383	348,6	1,64	5,60	1,41	247,1	1,46	5,12
RGT= 32/90	-5	23	486,5	1662	418,7	1,83	6,25	1,57	265,9	1,53	6,20
liquid temp	0	32	582,0	1988	500,9	2,05	6,99	1,76	284,5	1,60	7,48
Tliq= 55/131	7,2	45	748,2	2555	643,9	2,41	8,23	2,07	310,5	1,71	9,75

Model

Designation	DLE5.7CN	220-240V/50Hz	Conf. 2	Sales code:	102H4653
-------------	-----------------	----------------------	----------------	-------------	-----------------

Configuration

Motorconfiguration	RSIR
Power supply (nominal)	220-240V/50Hz 1~
Refrigerant	R290
Application	LBP+MBP
Voltage range	198-254V
Starting torque	LST
Approvals	VDE
	CCC

Electrical accessories / wiring diagram

RSIR

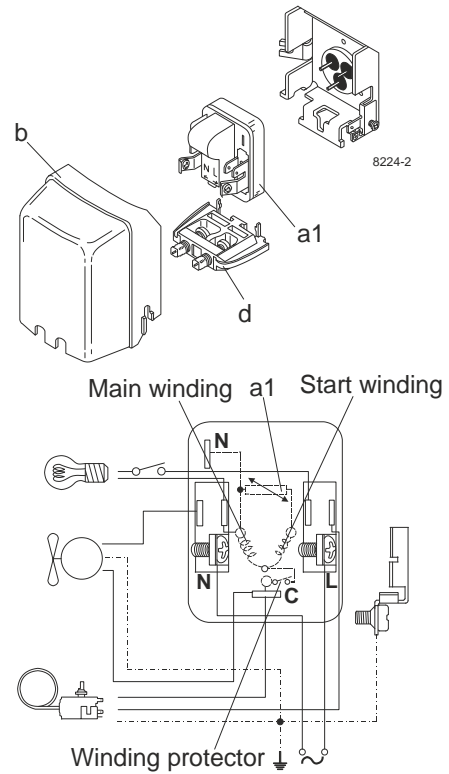

Ambient temperatures / system cooling

Ambient temperature min.:	10°C / 50°F
Ambient temperature max.:	43°C / 110°F

System cooling (n/a: outside limits)			
T ambient	LBP	MBP	HBP
32°C / 90°F	fan 3m/s	fan 3m/s	n/a
38°C / 100°F	fan 3m/s	fan 3m/s	n/a
43°C / 110°F	fan 3m/s	fan 3m/s	n/a

Operation pressure range

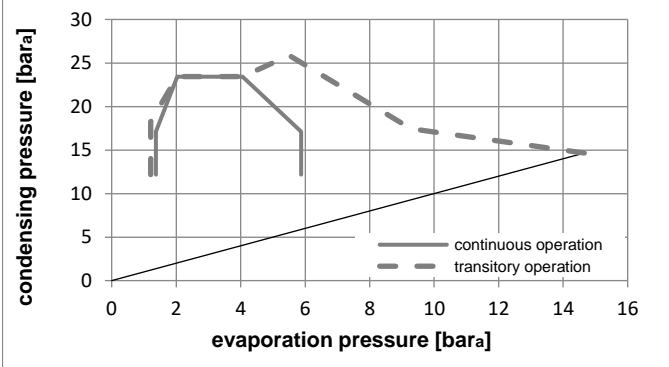
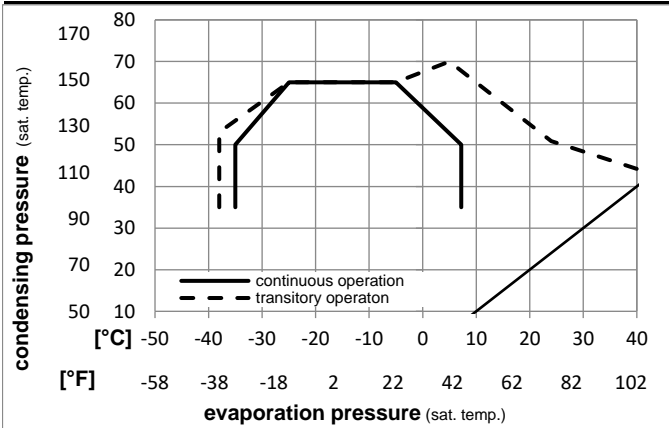

Components

a1	e-PTC starter (220V, 250hm, 4.8mm)	103N0050
b	plastic cover	103N0491
d	cord relief	103N1010

Model

Designation **DLE5.7CN 220-240V/50Hz** Conf. **2** Sales code: **102H4653**

Optimization + standard conditions

220-240V/50Hz 1~, RSIR, fan 3m/s, VDE, CCC

	Evaporating pressure (saturation temperature)				Condensing pressure (saturation temperature)						Power consumption			ASHRAE LBP
	pe	pc	RGT	Tliq	Cooling capacity			COP	EER	P1	I	Ref. mass flow		
	[°C]	[°F]	[°C]	[°F]	[W]	[Btu/h]	[kcal/h]	[W/W]	[Btu/Wh]	[kcal/Wh]	[W]	[A]	[kg/h]	
	-23,3	54,4	32,2	32,2	297,1	1015	255,7	1,52	5,21	1,31	194,9	1,28	3,01	ASHRAE LBP
	-10	130	90	90										
	-25	55	32	55	224,0	765	192,8	1,18	4,05	1,02	189,1	1,26	2,79	cecomaf LBP
	-13	131	89,6	131										
	-35	40	20	40	166,8	570	143,6	1,20	4,11	1,04	138,6	1,13	1,91	EN12900 LBP
	-31	104	68	104										
	-6,66	54,4	35	46,1	507,7	1734	437,0	1,97	6,72	1,69	258,2	1,50	5,79	ASHRAE MBP
	20	130	95	115										
	-10	55	32	55	405,1	1383	348,6	1,64	5,60	1,41	247,1	1,46	5,12	cecomaf MBP
	14	131	89,6	131										
	-10	45	20	45	446,0	1523	383,8	2,01	6,85	1,73	222,3	1,37	5,48	EN12900 MBP
	14	113	68	113										

Performance tables

220-240V/50Hz 1~, RSIR, fan 3m/s, VDE, CCC

	pe	Cooling capacity			COP	EER	P1	I	m		
	[°C]	[°F]	[W]	[Btu/h]	[kcal/h]	[W/W]	[Btu/Wh]	[kcal/Wh]	[W]	[A]	[kg/h]
[°C / °F]	-35	-31	162,1	554	139,5	1,14	3,90	0,98	141,9	1,13	1,82
cond. pressure	-25	-13	258,1	881	222,1	1,46	5,00	1,26	176,3	1,23	2,91
pc= 45/113	-15	5	384,5	1313	330,9	1,85	6,32	1,59	207,7	1,32	4,37
return gas temp.	-10	14	464,3	1586	399,6	2,09	7,13	1,80	222,3	1,37	5,31
RGT= 32/90	-5	23	557,9	1905	480,2	2,36	8,07	2,03	236,0	1,42	6,42
liquid temp	0	32	667,4	2279	574,4	2,68	9,16	2,31	248,8	1,47	7,74
Tliq= 45/113	7,2	45	857,2	2927	737,7	3,23	11,02	2,78	265,6	1,54	10,07
[°C / °F]	-35	-31	135,4	462	116,5	0,91	3,09	0,78	149,5	1,15	1,67
cond. pressure	-25	-13	224,0	765	192,8	1,18	4,05	1,02	189,1	1,26	2,79
pc= 55/131	-15	5	335,6	1146	288,8	1,47	5,03	1,27	228,0	1,39	4,22
return gas temp	-10	14	405,1	1383	348,6	1,64	5,60	1,41	247,1	1,46	5,12
RGT= 32/90	-5	23	486,5	1662	418,7	1,83	6,25	1,57	265,9	1,53	6,20
liquid temp	0	32	582,0	1988	500,9	2,05	6,99	1,76	284,5	1,60	7,48
Tliq= 55/131	7,2	45	748,2	2555	643,9	2,41	8,23	2,07	310,5	1,71	9,75

Model

Designation	DLE5.7CN	220-240V/50Hz	Conf. 3	Sales code:	102H4653
-------------	-----------------	----------------------	----------------	-------------	-----------------

Configuration

Motorconfiguration	RSCR
Power supply (nominal)	220-240V/50Hz 1~
Refrigerant	R290
Application	LBP+MBP
Voltage range	198-254V
Starting torque	LST
Approvals	VDE
	CCC

Electrical accessories / wiring diagram

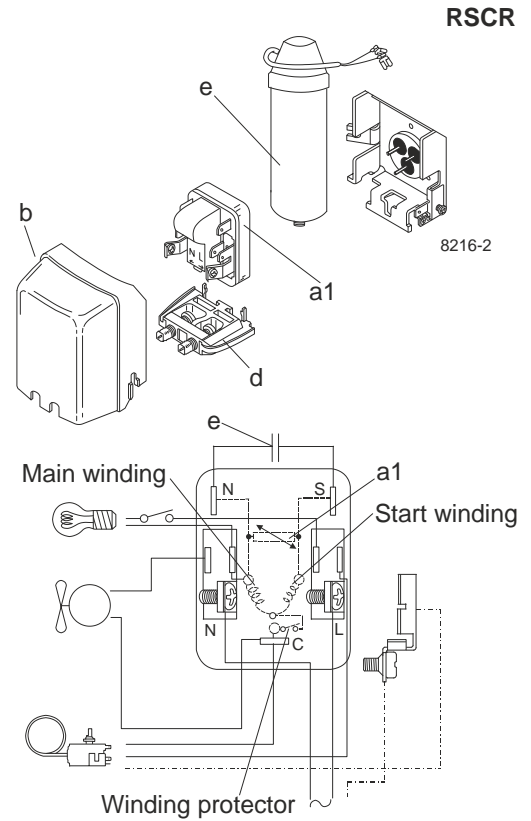

Ambient temperatures / system cooling

Ambient temperature min.:	10°C / 50°F
Ambient temperature max.:	43°C / 110°F

System cooling (n/a: outside limits)			
T ambient	LBP	MBP	HBP
32°C / 90°F	static	fan 3m/s	n/a
38°C / 100°F	static	fan 3m/s	n/a
43°C / 110°F	fan 3m/s	fan 3m/s	n/a

Operation pressure range

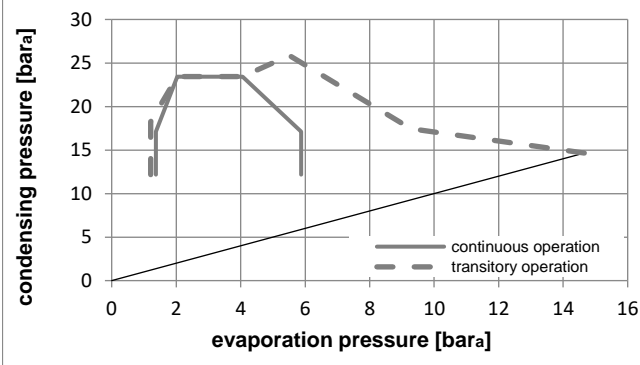
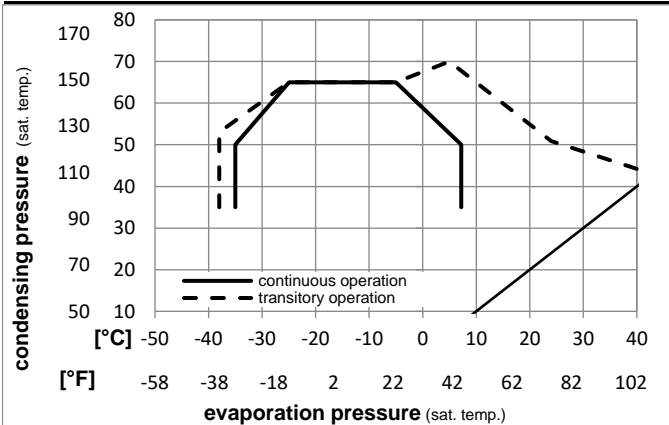

Components

a1	e-PTC starter (220V, 250hm, 4.8mm)	103N0050
e	run capacitor (5μF, 4.8mm)	117-7129
b	plastic cover	103N0491
d	cord relief	103N1010
	bracket for run capacitor	117-0300
	screw M4x8mm	117-0301

Model

Designation **DLE5.7CN 220-240V/50Hz** Conf. **3** Sales code: **102H4653**

Optimization + standard conditions

220-240V/50Hz 1~, RSCR, fan 3m/s, VDE, CCC

Evaporating pressure (saturation temperature)		Condensing pressure (saturation temperature)				Return gas temp.			Liquid temp.		Cooling capacity			COP	EER	Power consumption		Ref. mass flow m	ASHRAE LBP
pe	pc	RGT	Tliq	[W]	[Btu/h]	[kcal/h]	[W/W]	[Btu/Wh]	[kcal/Wh]	P1	I	[kg/h]							
[°C]	[°F]	[°C]	[°F]	[W]	[Btu/h]	[kcal/h]	[W/W]	[Btu/Wh]	[kcal/Wh]	[W]	[A]	[kg/h]							
-23,3	54,4	32,2	32,2	300,2	1025	258,3	1,59	5,44	1,37	188,6	0,94	3,04	ASHRAE LBP						
-10	130	90	90																
-25	55	32	55	226,3	773	194,8	1,24	4,23	1,06	183,0	0,93	2,82	cecomaf LBP						
-13	131	89,6	131																
-35	40	20	40	168,5	576	145,0	1,26	4,29	1,08	134,1	0,83	1,93	EN12900 LBP						
-31	104	68	104																
-6,66	54,4	35	46,1	513,0	1752	441,5	2,05	7,01	1,77	249,8	1,10	5,85	ASHRAE MBP						
20	130	95	115																
-10	55	32	55	409,3	1398	352,2	1,71	5,85	1,47	239,1	1,07	5,18	cecomaf MBP						
14	131	89,6	131																
-10	45	20	45	450,6	1539	387,8	2,10	7,16	1,80	215,1	1,01	5,53	EN12900 MBP						
14	113	68	113																

Performance tables

220-240V/50Hz 1~, RSCR, fan 3m/s, VDE, CCC

	pe	Cooling capacity			COP	EER	P1	I	m		
	[°C]	[°F]	[W]	[Btu/h]	[kcal/h]	[W/W]	[Btu/Wh]	[kcal/Wh]	[W]	[A]	[kg/h]
[°C / °F]	-35	-31	163,8	559	140,9	1,19	4,07	1,03	137,3	0,83	1,84
cond. pressure	-25	-13	260,7	890	224,4	1,53	5,22	1,32	170,6	0,90	2,94
pc= 45/113	-15	5	388,5	1327	334,3	1,93	6,60	1,66	201,0	0,97	4,42
return gas temp.	-10	14	469,1	1602	403,7	2,18	7,45	1,88	215,1	1,01	5,37
RGT= 32/90	-5	23	563,7	1925	485,1	2,47	8,43	2,12	228,3	1,05	6,49
liquid temp	0	32	674,3	2303	580,3	2,80	9,57	2,41	240,7	1,08	7,82
Tliq= 45/113	7,2	45	866,0	2958	745,3	3,37	11,51	2,90	257,0	1,13	10,17
[°C / °F]	-35	-31	136,8	467	117,7	0,95	3,23	0,81	144,7	0,85	1,69
cond. pressure	-25	-13	226,3	773	194,8	1,24	4,23	1,06	183,0	0,93	2,82
pc= 55/131	-15	5	339,0	1158	291,8	1,54	5,25	1,32	220,6	1,02	4,26
return gas temp	-10	14	409,3	1398	352,2	1,71	5,85	1,47	239,1	1,07	5,18
RGT= 32/90	-5	23	491,5	1679	423,0	1,91	6,52	1,64	257,3	1,12	6,26
liquid temp	0	32	588,0	2008	506,0	2,14	7,30	1,84	275,2	1,18	7,55
Tliq= 55/131	7,2	45	755,9	2581	650,5	2,52	8,59	2,17	300,4	1,26	9,85