



Compressor  
Voltage Code : FZ

# AJ4510P-FZ

High Temp. Commercial (HP)

220 - 240V 1~ 50 Hz

R452A / R404A / R448A / R449A / R455A / R454C AJ4510P-FZ3A

Conditions	Frequency	Nominal Cooling Capacity		Sound Power ISO3745 / ISO 3743-1
		Watts	BTU/h	
Standard TE / R452A	50 Hz	2641	9005	63 dBA
Standard TE / R404A	50 Hz	2594	8846	63 dBA
Standard TE / R448A	50 Hz	2700	9206	63 dBA
Standard TE / R449A	50 Hz	2698	9200	63 dBA
Standard TE / R455A	50 Hz	2647	9025	63 dBA
Standard TE / R454C	50 Hz	2326	7933	63 dBA

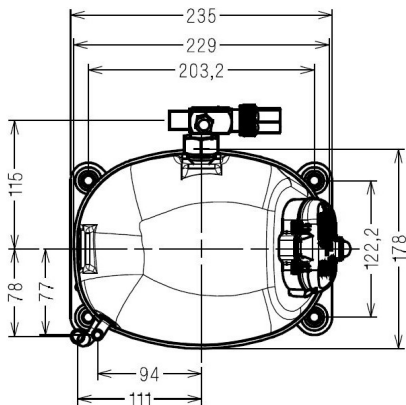
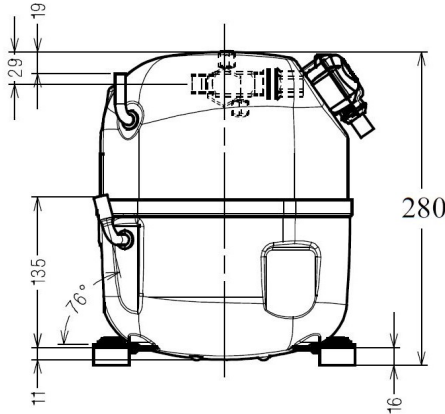

\* Standard TE : T°Cond. 54.5°C / T°Evap. 7.2°C / T°Superheat. 11.0°C  
T°Subcooling. 8.3K

Certificates :

<b>Displacement (cc)</b>	18,3
<b>Net Weight (Kg)</b>	21.5
<b>Oil Quantity (cc)</b>	475.0
<b>Oil Type</b>	Polyolester
<b>Expansion Device</b>	Capillary_Tube/Expansion_Valve
<b>Cooling</b>	Fan
<b>Main Winding (Ohm)</b>	2.9
<b>Start Winding (Ohm)</b>	8.8
<b>Current</b>	
RLA (A)	5,4
MCC (A)	8,4
LRA (A)	29.5
<b>Electrical Equipment</b>	CSR
<b>Overload</b>	MRA38128
Time Check	2.8s - 5.2s / 20.5 A
Open Temp	105° C
Close Temp	52° C
Optional	T0813
<b>Start Capacitor</b>	100 µF / 330 V
<b>Run Capacitor</b>	15 µF / 400 V
<b>Potential Relay</b>	RVA40**
Pick Up	280/310V
Drop Out	60/121V
<b>Refrigerating connection for</b>	
Suction Tube	15.9 (5/8")
Discharge Tube	7.9 (5/16")
Process Tube	6.35 (1/4")

Note : Tecumseh reserves the right to change information contained in this document without notification.



**Tecumseh**

<b>AJ4510P-FZ</b>	<b>Tension FZ : 220 - 240V 1~ 50 Hz</b>
-------------------	---

Les performances sont données dans les <b>conditions Standard TE</b> :	Surchauffe :	11.0 K
Condition Mid	Sous refroidissement :	8.3 K
The performance data are in <b>Standard TE conditions</b> :	Superheat :	11.0 K
Mid Condition	Subcooling :	8.3 K

<b>50 Hz R452A</b>											
											<b>N°3642</b>
4   T condensation	5   T évaporation	(°C)	-25	-20	-15	-10	-5	0	5	10	15
<b>30</b>	1   P frigorifique	(Watt)		1188	1543	1973	2492	3112	3849	4716	5728
	2   P absorbée	(W)		633	691	744	792	834	870	898	918
	3   I absorbée	(A)		3.03	3.29	3.52	3.75	3.96	4.16	4.35	4.52
<b>40</b>	1   P frigorifique	(Watt)			1269	1639	2083	2616	3252	4005	4894
	2   P absorbée	(W)			735	807	874	937	994	1044	1088
	3   I absorbée	(A)			3.45	3.78	4.10	4.40	4.69	4.97	5.23
<b>50</b>	1   P frigorifique	(Watt)				1305	1676	2122	2657	3298	4065
	2   P absorbée	(W)				855	942	1026	1105	1179	1246
	3   I absorbée	(A)				3.99	4.40	4.79	5.17	5.54	5.90
<b>60</b>	1   P frigorifique	(Watt)					1280	1642	2081	2615	3268
	2   P absorbée	(W)					995	1101	1203	1300	1393
	3   I absorbée	(A)					4.64	5.13	5.61	6.07	6.52

<b>50 Hz R404A</b>											
											<b>N°3641</b>
4   T condensation	5   T évaporation	(°C)	-25	-20	-15	-10	-5	0	5	10	15
<b>30</b>	1   P frigorifique	(Watt)	924	1207	1552	1969	2471	3070	3778	4611	5583
	2   P absorbée	(W)	586	645	701	752	797	836	868	891	907
	3   I absorbée	(A)	2.86	3.12	3.35	3.58	3.78	3.97	4.15	4.31	4.46
<b>40</b>	1   P frigorifique	(Watt)		984	1285	1645	2076	2590	3201	3924	4777
	2   P absorbée	(W)		679	751	819	883	941	994	1039	1076
	3   I absorbée	(A)		3.21	3.53	3.85	4.14	4.42	4.69	4.94	5.17
<b>50</b>	1   P frigorifique	(Watt)			1014	1317	1677	2106	2619	3233	3966
	2   P absorbée	(W)			787	874	956	1035	1108	1176	1237
	3   I absorbée	(A)			3.68	4.08	4.46	4.84	5.19	5.53	5.85
<b>60</b>	1   P frigorifique	(Watt)				992	1281	1628	2045	2551	3169
	2   P absorbée	(W)				915	1018	1117	1213	1303	1388
	3   I absorbée	(A)				4.27	4.75	5.21	5.65	6.08	6.50

1 = cooling capacity 2 = power input 3 = current 4 = condensing temperature 5 = evaporating temperature

**Nota : Tecumseh se réserve le droit de modifier les informations contenues dans ce document sans préavis.**

**Note : Tecumseh reserves the right to change information contained in this document without notification.**

© 2024 Tecumseh Products Company  
All rights reserved



**Tecumseh**

<b>AJ4510P-FZ</b>	<b>Tension FZ : 220 - 240V 1~ 50 Hz</b>
-------------------	---

Les performances sont données dans les <b>conditions Standard TE</b> :	Surchauffe :	11.0 K
Condition Mid	Sous refroidissement :	8.3 K
The performance data are in <b>Standard TE conditions</b> :	Superheat :	11.0 K
Mid Condition	Subcooling :	8.3 K

<b>50 Hz R448A (*)</b>											
											<b>N°3643</b>
4   T condensation	5   T évaporation	(°C)	-25	-20	-15	-10	-5	0	5	10	15
<b>30</b>	1   P frigorifique	(Watt)	853	1143	1495	1922	2434	3046	3769	4619	5607
	2   P absorbée	(W)	545	602	657	708	755	796	830	856	873
	3   I absorbée	(A)	2.63	2.88	3.12	3.35	3.57	3.78	3.97	4.15	4.30
<b>40</b>	1   P frigorifique	(Watt)		933	1242	1612	2057	2589	3221	3969	4847
	2   P absorbée	(W)		634	704	773	838	898	953	1000	1039
	3   I absorbée	(A)		2.98	3.30	3.62	3.93	4.22	4.50	4.76	5.00
<b>50</b>	1   P frigorifique	(Watt)			992	1309	1687	2141	2684	3331	4100
	2   P absorbée	(W)			738	825	911	993	1070	1142	1206
	3   I absorbée	(A)			3.44	3.85	4.25	4.64	5.01	5.37	5.71
<b>60</b>	1   P frigorifique	(Watt)				1017	1332	1710	2166	2716	3378
	2   P absorbée	(W)				862	971	1077	1179	1276	1368
	3   I absorbée	(A)				4.03	4.53	5.02	5.49	5.96	6.40

<b>50 Hz R449A (*)</b>											
											<b>N°3640</b>
4   T condensation	5   T évaporation	(°C)	-25	-20	-15	-10	-5	0	5	10	15
<b>30</b>	1   P frigorifique	(Watt)	850	1140	1492	1919	2432	3044	3769	4620	5611
	2   P absorbée	(W)	544	601	656	708	755	796	830	856	872
	3   I absorbée	(A)	2.63	2.87	3.12	3.35	3.57	3.78	3.97	4.15	4.30
<b>40</b>	1   P frigorifique	(Watt)		930	1239	1609	2055	2587	3221	3970	4850
	2   P absorbée	(W)		633	704	772	837	898	952	1000	1039
	3   I absorbée	(A)		2.98	3.30	3.62	3.92	4.22	4.50	4.76	5.00
<b>50</b>	1   P frigorifique	(Watt)			988	1305	1684	2138	2682	3331	4102
	2   P absorbée	(W)			737	825	910	992	1070	1141	1206
	3   I absorbée	(A)			3.44	3.85	4.25	4.64	5.01	5.37	5.71
<b>60</b>	1   P frigorifique	(Watt)				1013	1328	1706	2163	2714	3378
	2   P absorbée	(W)				862	970	1076	1179	1276	1368
	3   I absorbée	(A)				4.02	4.52	5.02	5.49	5.96	6.40

1 = cooling capacity 2 = power input 3 = current 4 = condensing temperature 5 = evaporating temperature

(\*) Veuillez vous référer strictement aux Recommandations d'Utilisation et Bulletins Marketing Tecumseh du fait de la température de reflux élevée pour les applications LBP.  
 (\*) Due to very high discharge temperature especially on LBP conditions, please strictly refer to Tecumseh Guidelines & Marketing Bulletin when using this refrigerant.

**Nota : Tecumseh se réserve le droit de modifier les informations contenues dans ce document sans préavis.**  
**Note : Tecumseh reserves the right to change information contained in this document without notification.**

© 2024 Tecumseh Products Company  
All rights reserved



**Tecumseh**

<b>AJ4510P-FZ</b>	<b>Tension FZ : 220 - 240V 1~ 50 Hz</b>
-------------------	---

Les performances sont données dans les **conditions Standard TE** :  
 Condition Mid

The performance data are in **Standard TE conditions** :  
 Mid Condition

Surchauffe : 11.0 K  
 Sous refroidissement : 8.3 K  
 Superheat : 11.0 K  
 Subcooling : 8.3 K

© 2024 Tecumseh Products Company  
All rights reserved

**50 Hz R455A**

**N°3276**

4   T condensation	5   T évaporation	(°C)	-25	-20	-15	-10	-5	0	5	10	15
<b>30</b>	1   P frigorifique	(Watt)		1145	1497	1920	2426	3027	3735	4564	5536
	2   P absorbée	(W)		609	661	707	748	786	823	861	901
	3   I absorbée	(A)		2.94	3.18	3.40	3.59	3.76	3.91	4.03	4.14
<b>40</b>	1   P frigorifique	(Watt)			1219	1587	2027	2553	3176	3912	4777
	2   P absorbée	(W)			703	769	829	882	933	981	1030
	3   I absorbée	(A)			3.37	3.68	3.96	4.21	4.44	4.63	4.80
<b>50</b>	1   P frigorifique	(Watt)				1265	1641	2092	2632	3276	4040
	2   P absorbée	(W)				812	896	971	1041	1107	1170
	3   I absorbée	(A)				3.87	4.27	4.63	4.95	5.25	5.51
<b>60</b>	1   P frigorifique	(Watt)					1277	1655	2114	2668	3336
	2   P absorbée	(W)					940	1044	1140	1229	1313
	3   I absorbée	(A)					4.48	4.98	5.43	5.84	6.21

**50 Hz R454C**

**N°3277**

4   T condensation	5   T évaporation	(°C)	-25	-20	-15	-10	-5	0	5	10	15
<b>30</b>	1   P frigorifique	(Watt)		1024	1325	1691	2133	2664	3296	4040	4910
	2   P absorbée	(W)		557	606	652	695	731	760	779	788
	3   I absorbée	(A)		2.71	2.94	3.15	3.34	3.50	3.62	3.68	3.67
<b>40</b>	1   P frigorifique	(Watt)			1094	1407	1786	2243	2790	3441	4209
	2   P absorbée	(W)			650	709	765	815	859	893	917
	3   I absorbée	(A)			3.12	3.40	3.65	3.89	4.08	4.23	4.32
<b>50</b>	1   P frigorifique	(Watt)				1141	1461	1847	2313	2874	3545
	2   P absorbée	(W)				759	833	902	965	1019	1063
	3   I absorbée	(A)				3.62	3.96	4.29	4.58	4.84	5.04
<b>60</b>	1   P frigorifique	(Watt)					1159	1480	1870	2345	2924
	2   P absorbée	(W)					874	967	1052	1131	1199
	3   I absorbée	(A)					4.18	4.62	5.03	5.41	5.75

1 = cooling capacity 2 = power input 3 = current 4 = condensing temperature 5 = evaporating temperature

**Nota : Tecumseh se réserve le droit de modifier les informations contenues dans ce document sans préavis.**

**Note : Tecumseh reserves the right to change information contained in this document without notification.**